

WARMFLOW
Zeno

AIR SOURCE HEAT PUMP

**ZENO R290 AIR SOURCE HEAT PUMP
INSTALLATION SCHEMATICS**

www.warmflow.co.uk



1 x ASHP + 1 x CYLINDER + 1 x BUFFER + RADIATORS - SCHEMATIC

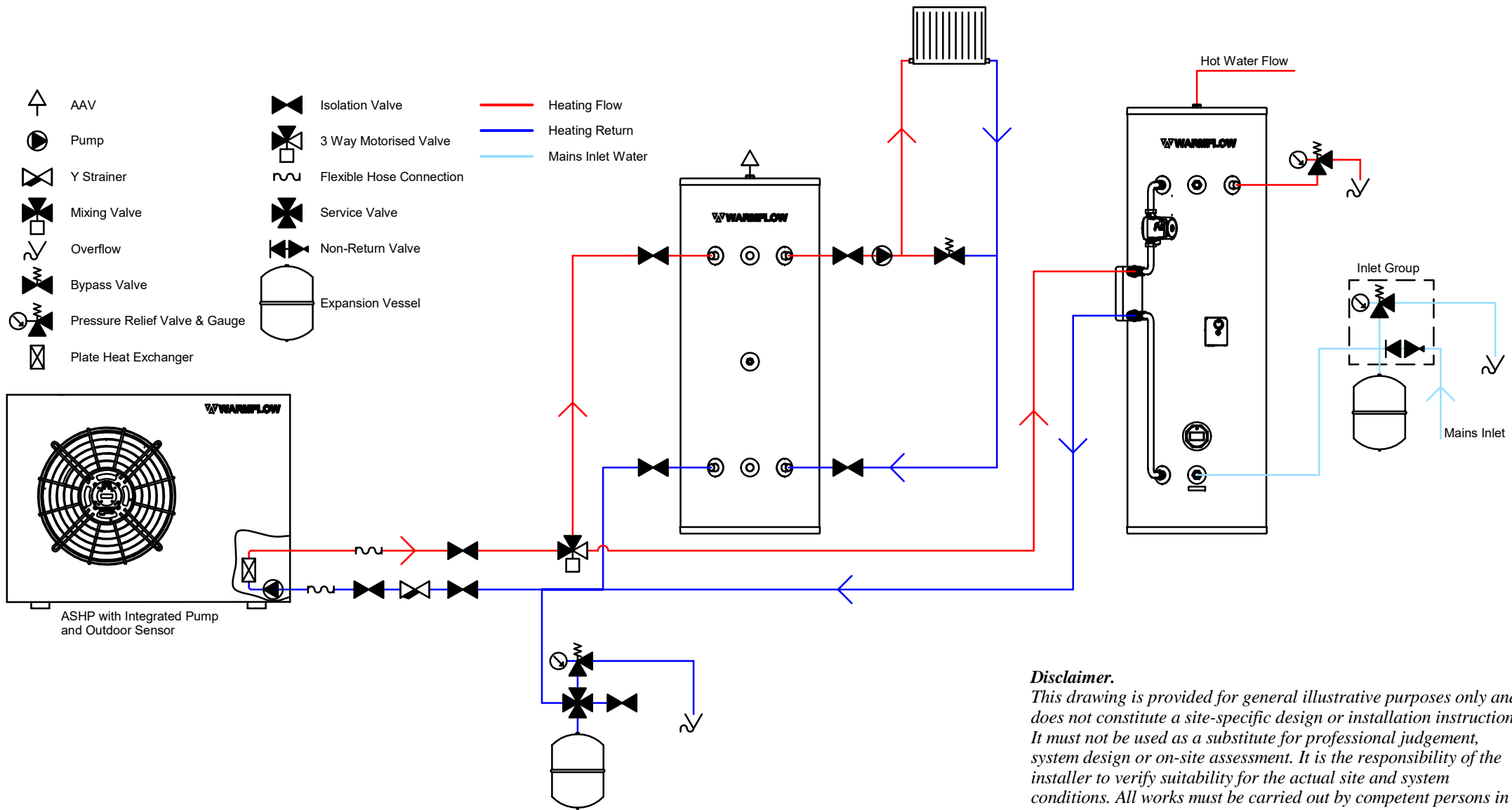

Disclaimer.

This drawing is provided for general illustrative purposes only and does not constitute a site-specific design or installation instruction. It must not be used as a substitute for professional judgement, system design or on-site assessment. It is the responsibility of the installer to verify suitability for the actual site and system conditions. All works must be carried out by competent persons in accordance with applicable regulations and standards. Refer to full installation disclaimer. No liability is accepted by the manufacturer for any loss or damage arising from reliance on this drawing.

1 x ASHP + 1 x CYLINDER + 1 x VOLUMISER + RADIATORS + UFH - SCHEMATIC

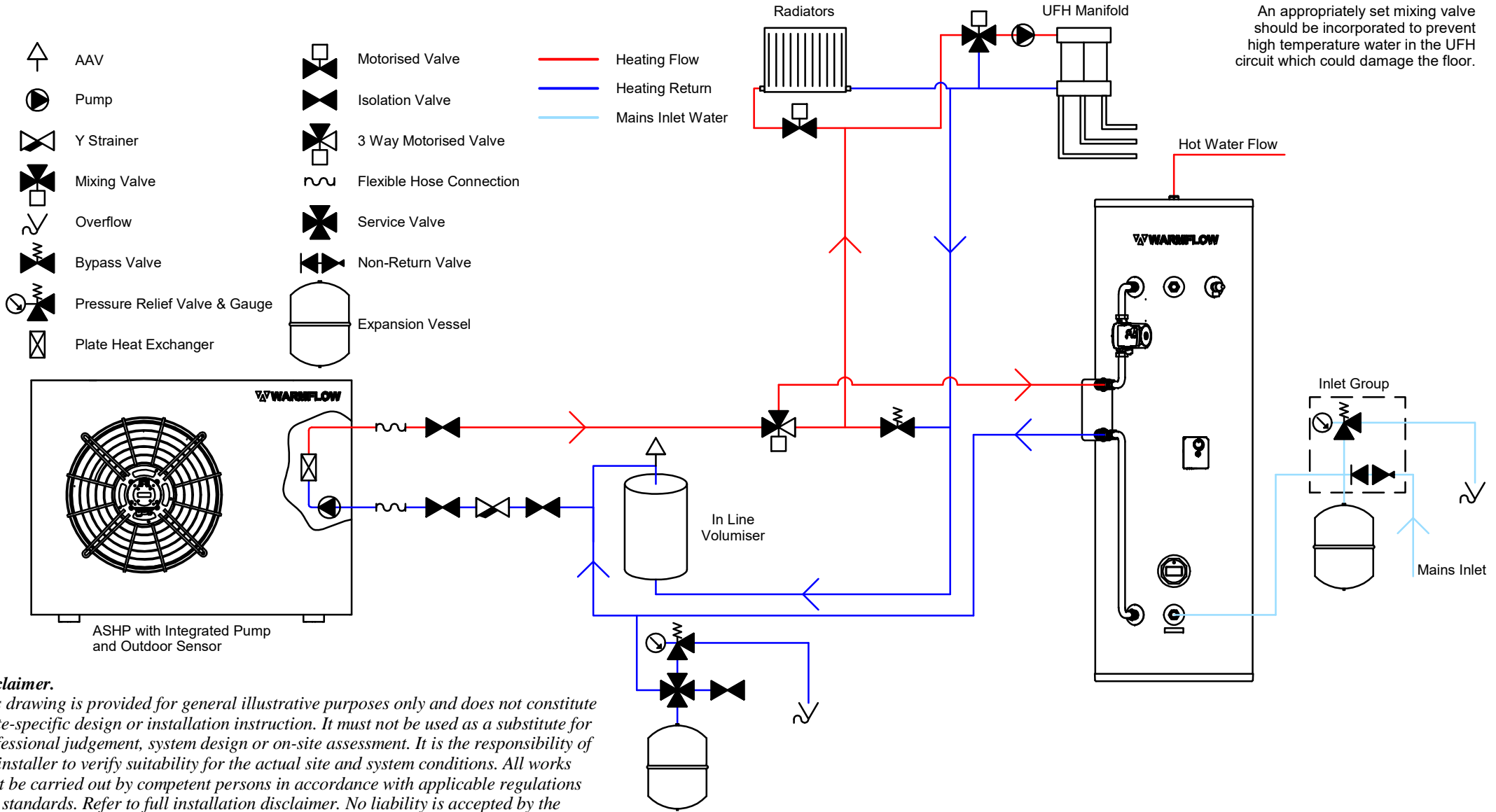

Disclaimer.
 This drawing is provided for general illustrative purposes only and does not constitute a site-specific design or installation instruction. It must not be used as a substitute for professional judgement, system design or on-site assessment. It is the responsibility of the installer to verify suitability for the actual site and system conditions. All works must be carried out by competent persons in accordance with applicable regulations and standards. Refer to full installation disclaimer. No liability is accepted by the manufacturer for any loss or damage arising from reliance on this drawing.

1 x ASHP + 1 x CYLINDER + 1 x VOLUMISER + UFH - SCHEMATIC

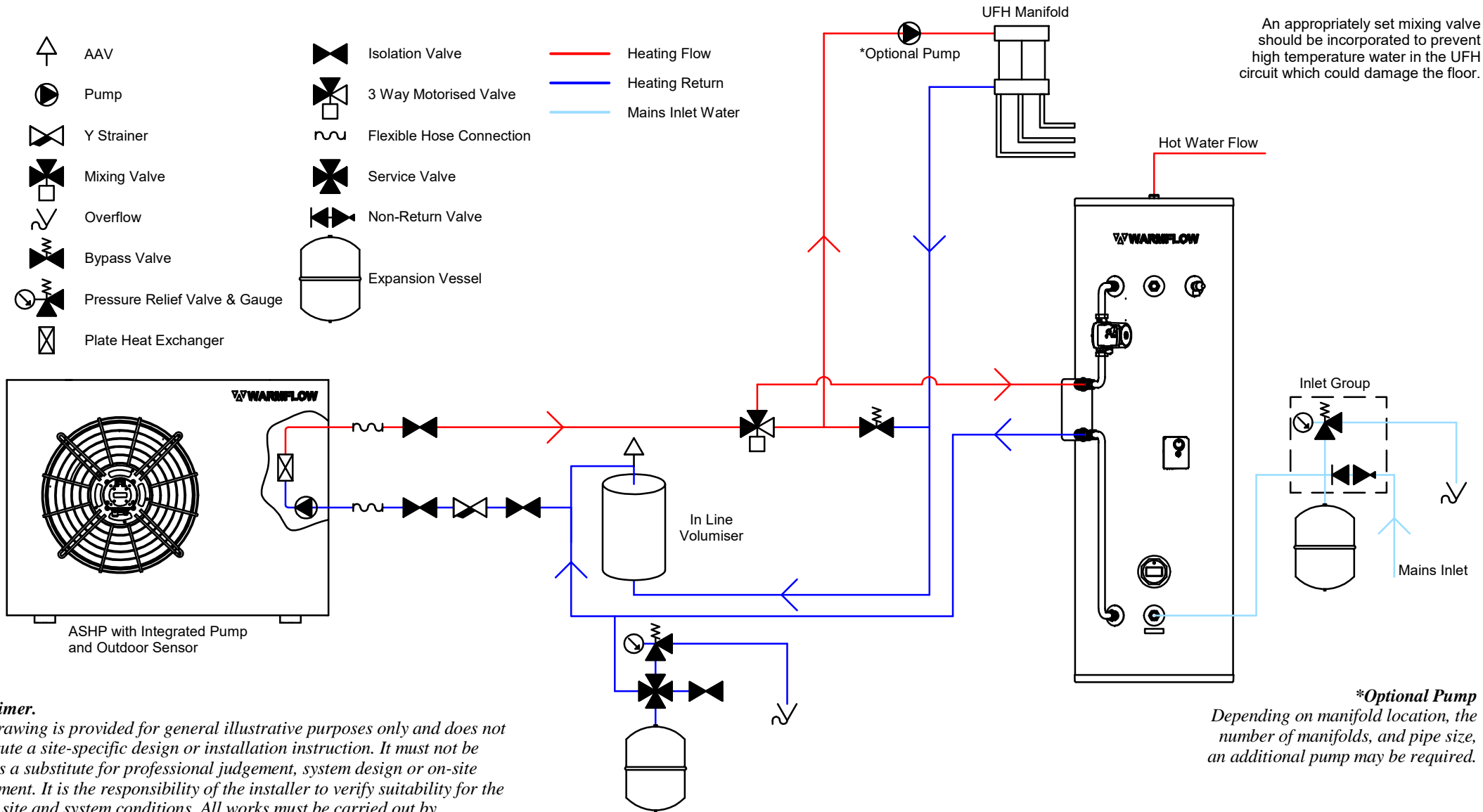
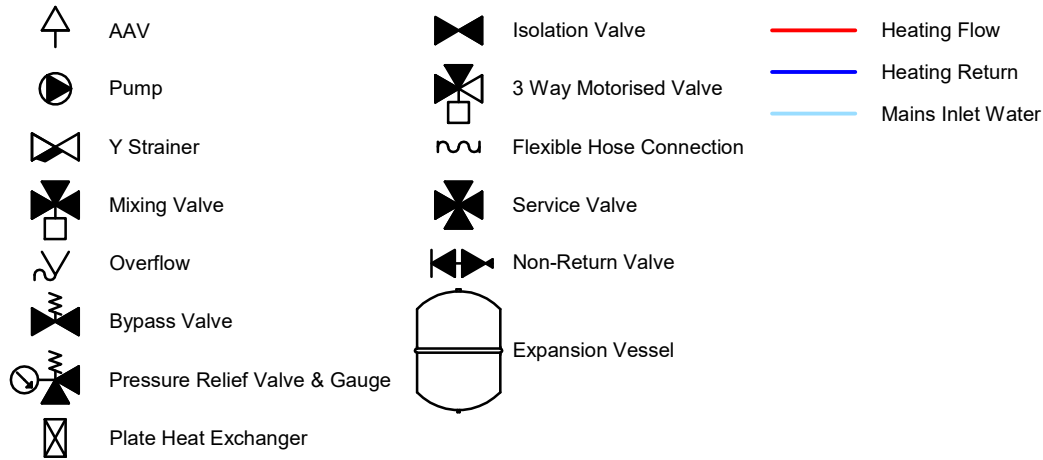

An appropriately set mixing valve should be incorporated to prevent high temperature water in the UFH circuit which could damage the floor.

***Optional Pump**
Depending on manifold location, the number of manifolds, and pipe size, an additional pump may be required.

Disclaimer.
This drawing is provided for general illustrative purposes only and does not constitute a site-specific design or installation instruction. It must not be used as a substitute for professional judgement, system design or on-site assessment. It is the responsibility of the installer to verify suitability for the actual site and system conditions. All works must be carried out by competent persons in accordance with applicable regulations and standards. Refer to full installation disclaimer. No liability is accepted by the manufacturer for any loss or damage arising from reliance on this drawing.

2 x ASHP + 1 x BUFFER TANK + HEATING SYSTEM - SCHEMATIC

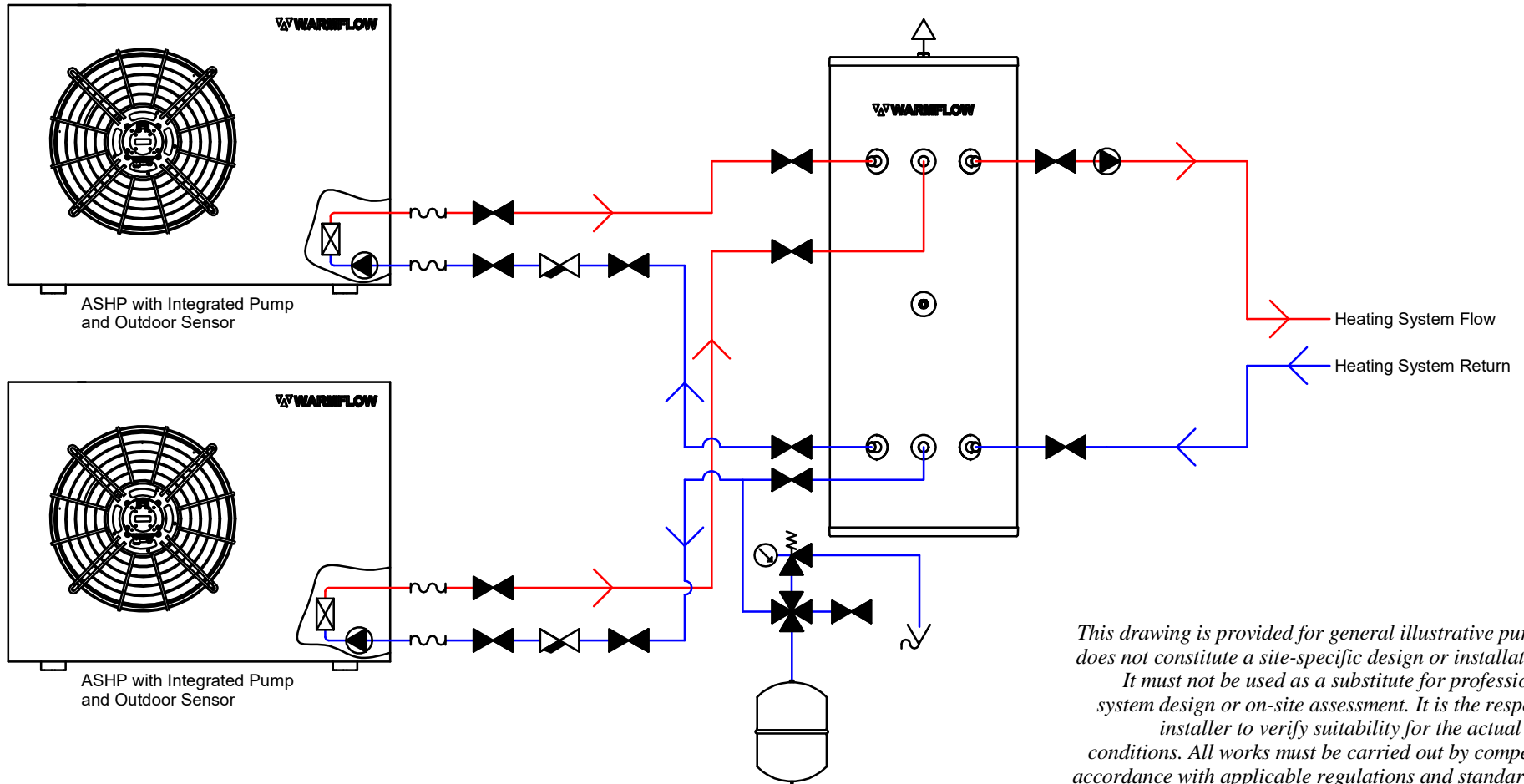
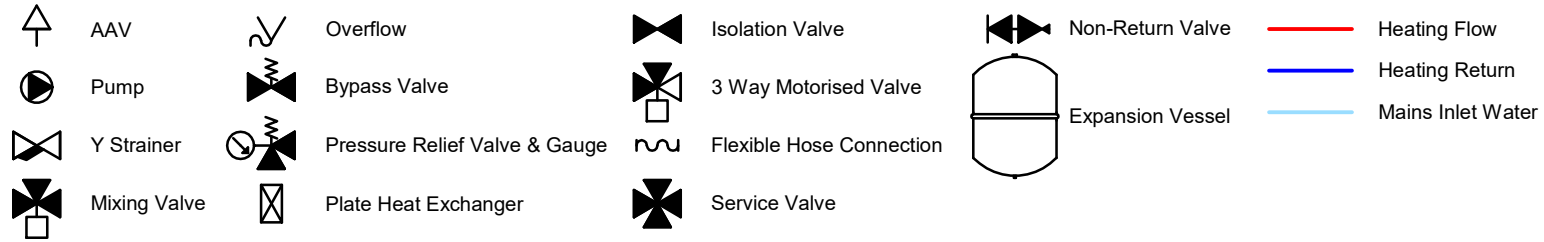

Disclaimer.
 This drawing is provided for general illustrative purposes only and does not constitute a site-specific design or installation instruction. It must not be used as a substitute for professional judgement, system design or on-site assessment. It is the responsibility of the installer to verify suitability for the actual site and system conditions. All works must be carried out by competent persons in accordance with applicable regulations and standards. Refer to full installation disclaimer. No liability is accepted by the manufacturer for any loss or damage arising from reliance on this drawing.

2 x ASHP + 2 x CYLINDER + 1 x BUFFER + RADIATORS - SCHEMATIC

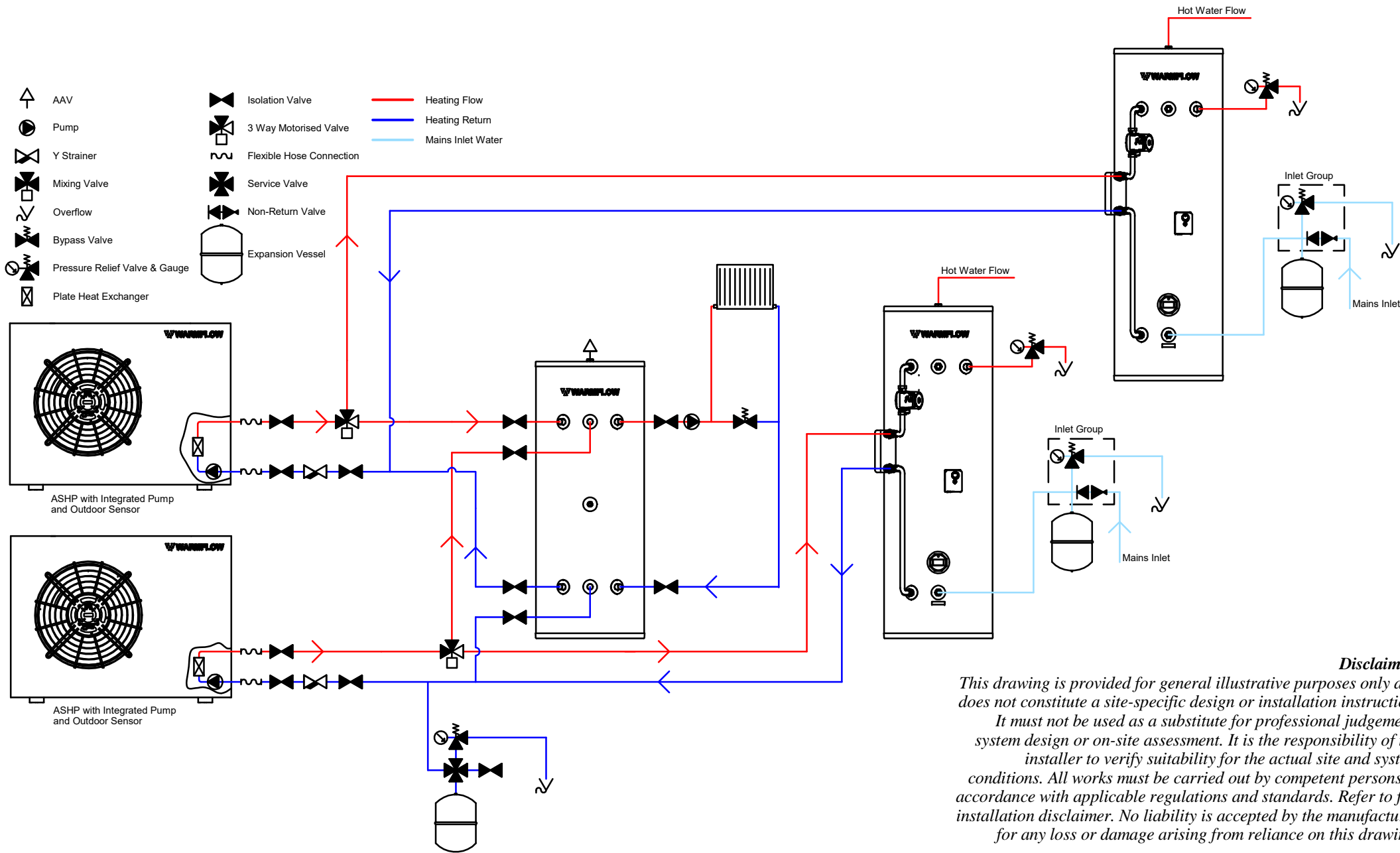

- AAV
- Pump
- Y Strainer
- Mixing Valve
- Overflow
- Bypass Valve
- Pressure Relief Valve & Gauge
- Plate Heat Exchanger
- Isolation Valve
- 3 Way Motorised Valve
- Flexible Hose Connection
- Service Valve
- Non-Return Valve
- Expansion Vessel

- Heating Flow
- Heating Return
- Mains Inlet Water

Disclaimer.
 This drawing is provided for general illustrative purposes only and does not constitute a site-specific design or installation instruction. It must not be used as a substitute for professional judgement, system design or on-site assessment. It is the responsibility of the installer to verify suitability for the actual site and system conditions. All works must be carried out by competent persons in accordance with applicable regulations and standards. Refer to full installation disclaimer. No liability is accepted by the manufacturer for any loss or damage arising from reliance on this drawing.

2 x ASHP + 1 x CYLINDER + 1 x BUFFER + UFH - SCHEMATIC

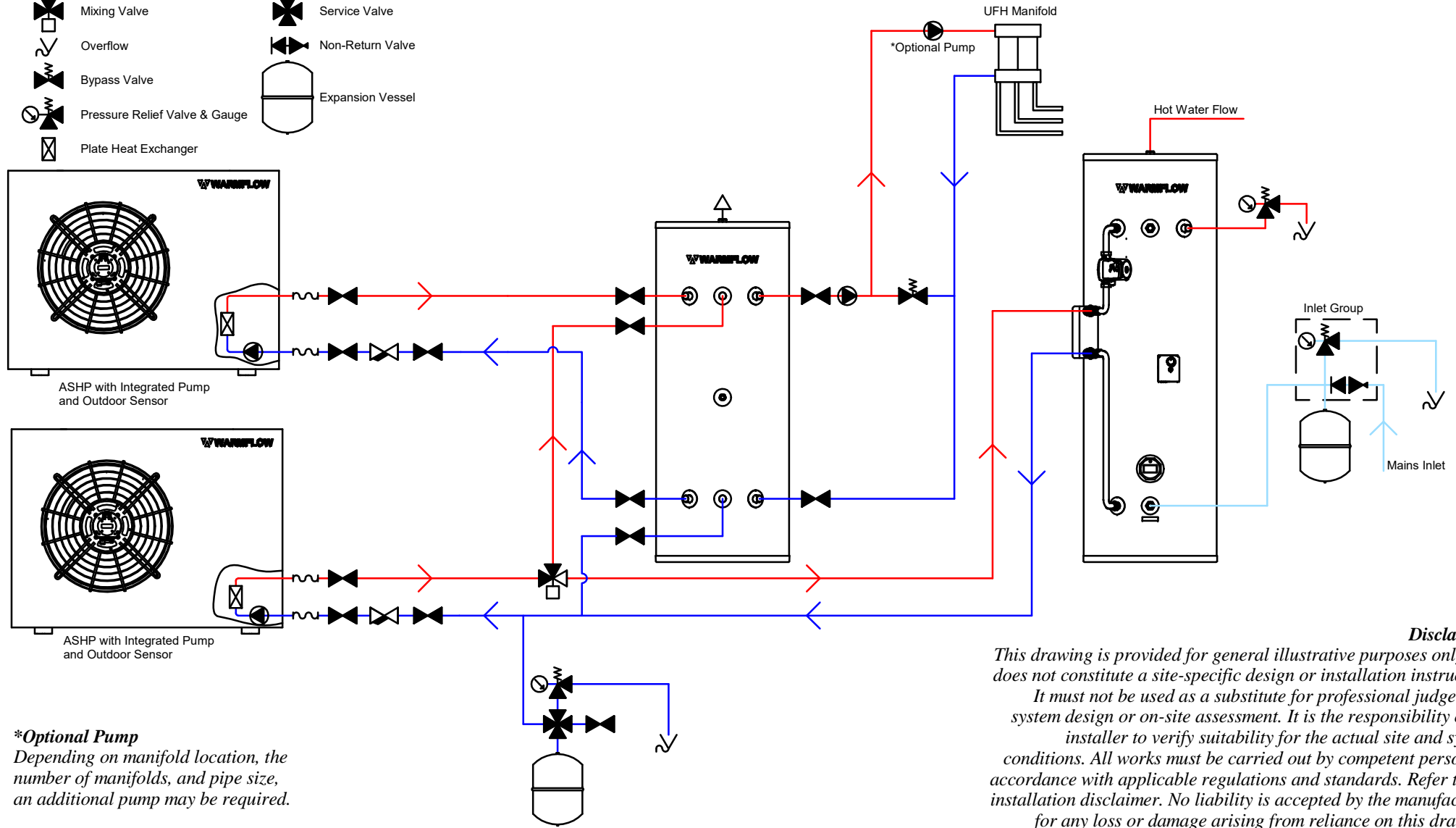
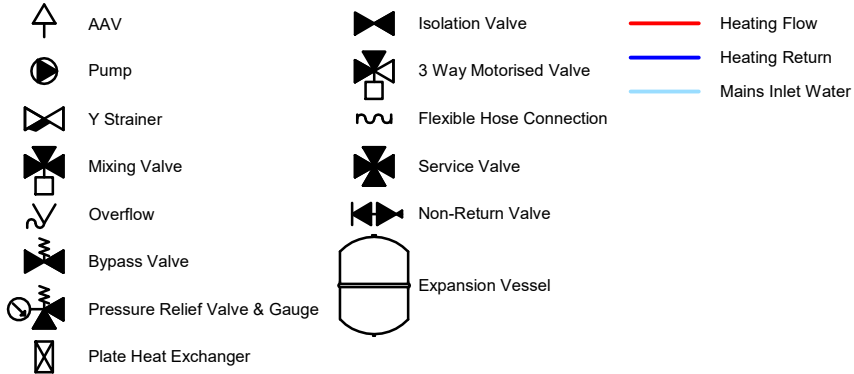

***Optional Pump**
 Depending on manifold location, the number of manifolds, and pipe size, an additional pump may be required.

Disclaimer.
 This drawing is provided for general illustrative purposes only and does not constitute a site-specific design or installation instruction. It must not be used as a substitute for professional judgement, system design or on-site assessment. It is the responsibility of the installer to verify suitability for the actual site and system conditions. All works must be carried out by competent persons in accordance with applicable regulations and standards. Refer to full installation disclaimer. No liability is accepted by the manufacturer for any loss or damage arising from reliance on this drawing.

AS0X-R290 - INSTALLER WIRING CENTRE CONNECTIONS

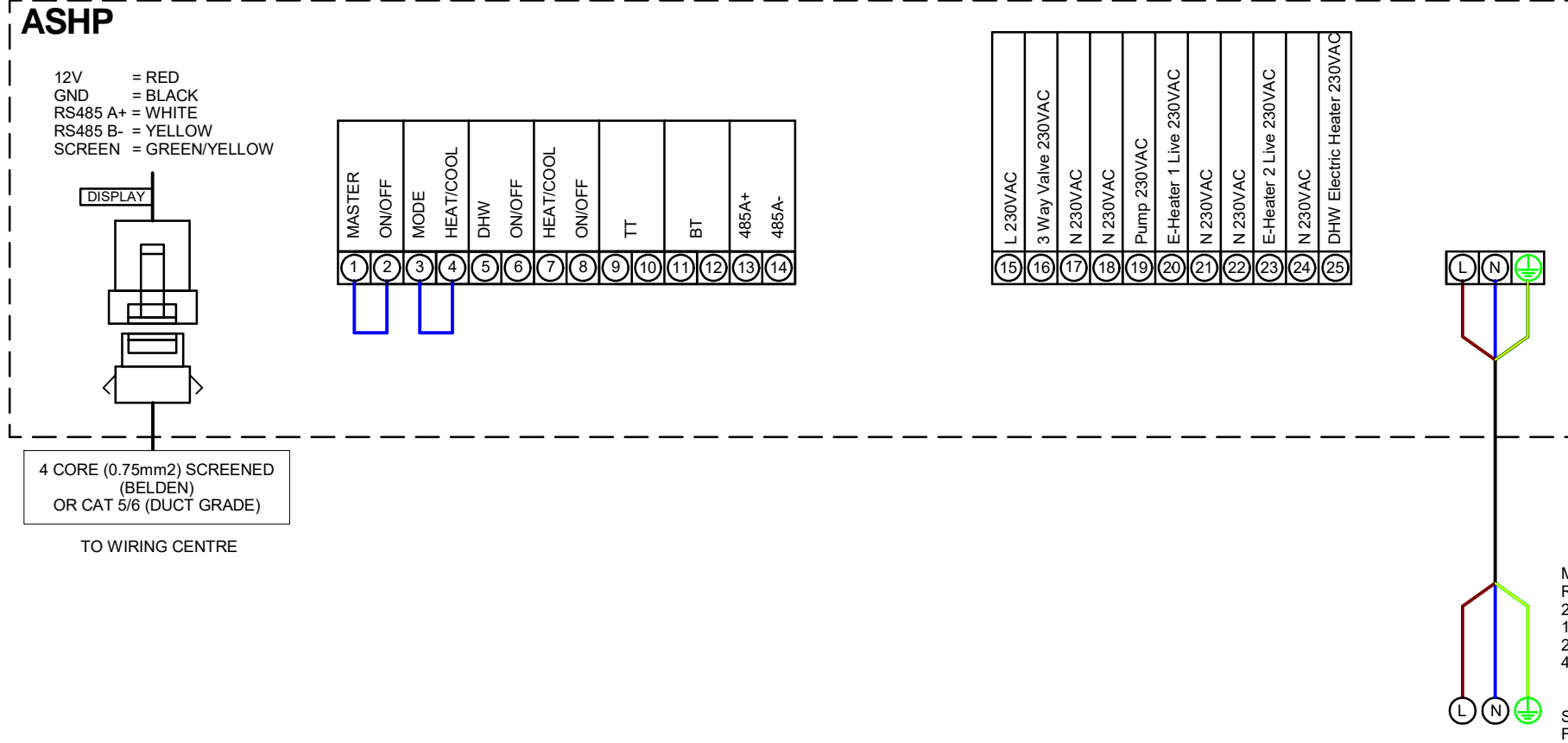

WIRING CENTRE

BP1000
MAIN BOARD

ZH1002
SENSORS &
VOLT FREE
CONNECTIONS

ZH1004
230V CONNECTIONS

ZH1005
NOT USED

AS0X-R290 - INSTALLER WIRING CENTRE

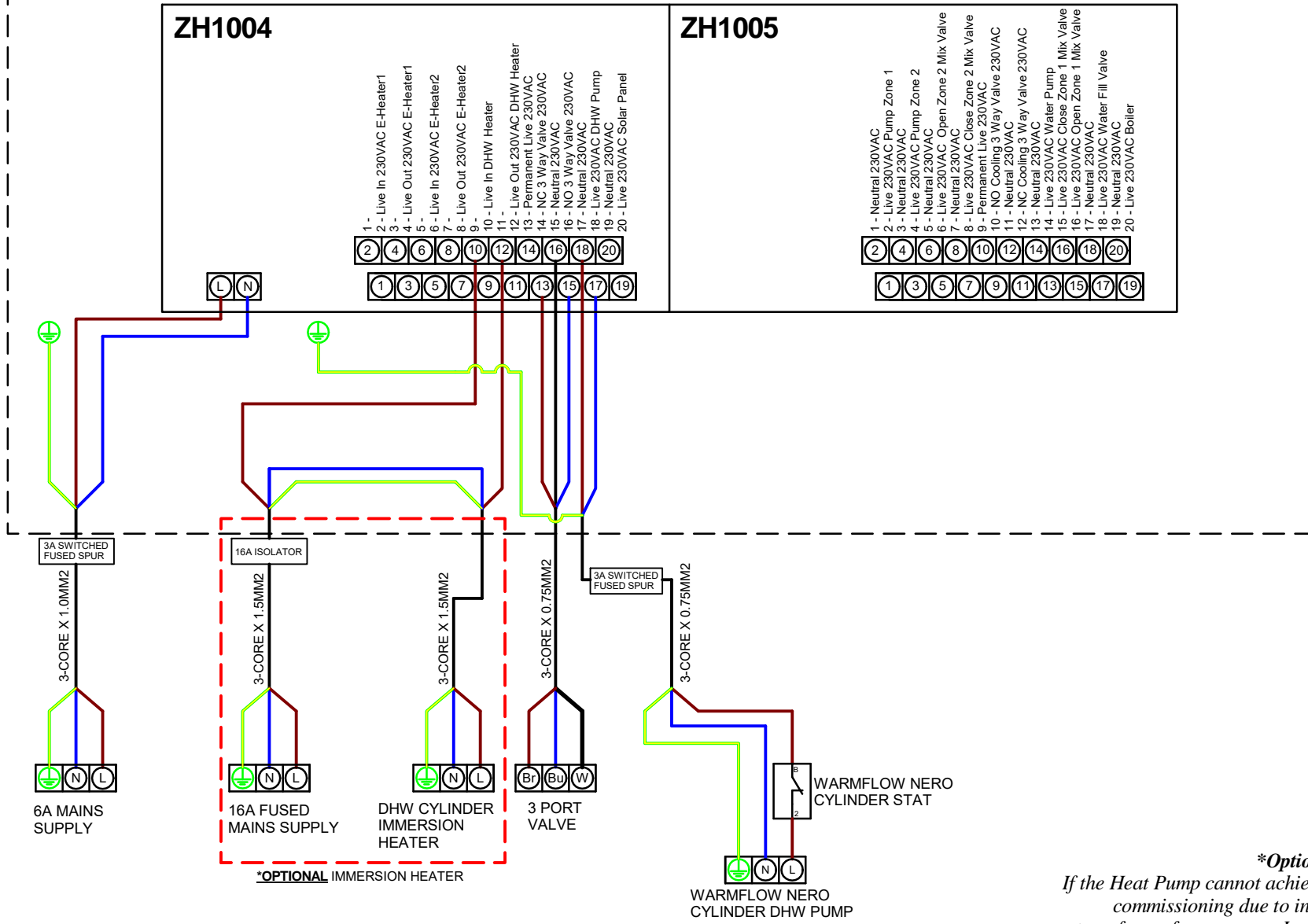

***Optional Immersion Heater**
 If the Heat Pump cannot achieve 60 degrees DHW on commissioning due to insufficient cylinder heat transfer surface area, an Immersion Heater must be wired via a contactor for Legionella cycle purposes.

AS0X-R290 - INSTALLER WIRING CENTRE

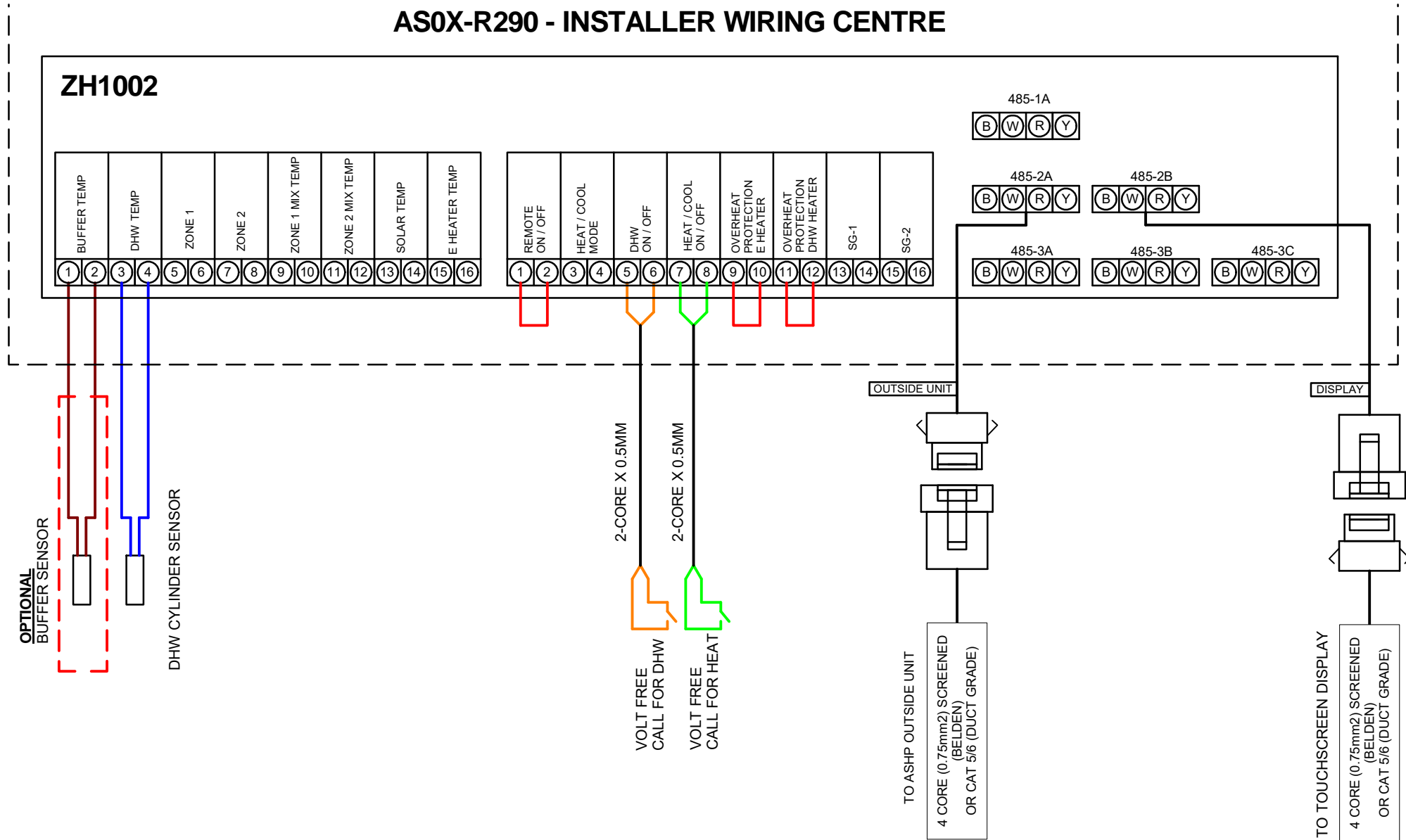

AS0X-R290 - INSTALLER WIRING CONNECTIONS (WITHOUT WIRING CENTRE)



ASHP OUTSIDE UNIT

12V = RED
 GND = BLACK
 RS485 A+ = WHITE
 RS485 B- = YELLOW
 SCREEN = GREEN/YELLOW

TT = DHW CYLINDER SENSOR
 BT = BUFFER SENSOR

